

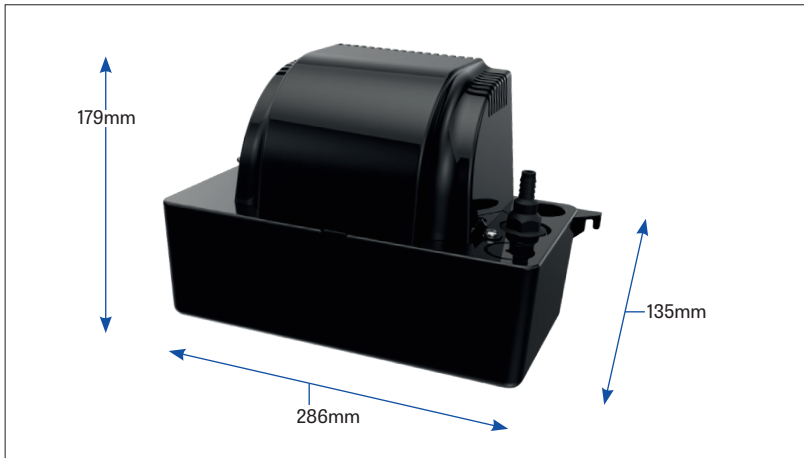

PH-2L-SS-BLACK - 2 LITRE CONDENSATE PUMP



The 7.2 metre discharge lift helps with the flexibility of the installation. Suitable for both floor and wall mounting and comes with a quick release check valve. Ideal for cassette air conditioning and refrigeration.

FEATURES

- 650ml drink cycle
- Outlet (3/8" & 1/4")
- High-level safety switch
- Floor or wall-mounted

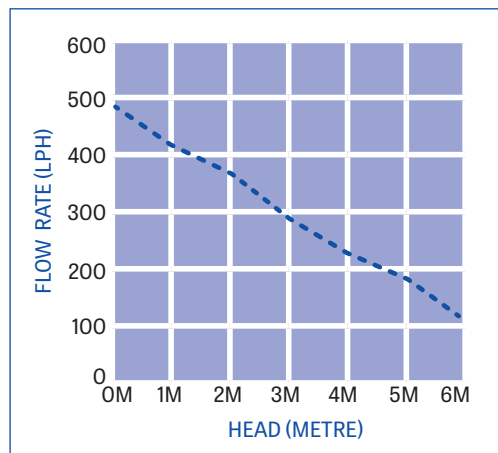

THE PACKAGE

- 2 Litre tank pump
- Quick release 1/4 turn check valve
- Installation instructions



MAX. FLOW 480 LPH



TANK CAP. 1.8



DECIBEL RATING 43 dB(A)

Part code	Max. lift	Discharge size	PSI	Watts	IP	Amps	Volts	Hz
PH-2L-SS-BLACK	7.2m	3/8" / 1/4"	8.5	75.8	20	0.7	240V	50Hz

High level alarm	Inlet height	Weight	Cable length	Drink cycle	On level	Off level	Reserve before overflow	Alarm level
Volt free	82.5mm	1.93kg	1.8m	650ml	30mm	9mm	580ml	50mm

PUMPS PH-2L-SS-BLACK

2 Litre Condensate Pump

The DiversiTech International sales team are available to answer your questions or queries on this product. Our experts are waiting for your call +44 (0)115 900 5858 or if you prefer send an email to sales@diversitech.com or visit www.diversitech.global